

CHIKO U2V STEEL GROUND MOUNT

The Chiko U2V Ground Mounting system has been designed and engineered for large arrays, providing a cost effective installation option. The design can adapt to multiple module sizes and tilts, based on terrain and geographic locations. Multiple foundation options can be used to include concrete blocks and ground screws.

PRODUCT LINE

Item	Product Name
CK-U2V-20	Chiko U2V System 20 Degree
CK-U2V-30	Chiko U2V System 30 Degree
CK-U2V-45	Chiko U2V System 45 Degree

TECHNICAL DATA

Main Material : Q235/Q345 Hot Dip Galvanized Steel
 Wind Velocity : Up to 150MPH
 Snow Load : Up to 80PSF

ADVANTAGES

- Easy installation
- Safety and reliability
- High class galvanized
- Cost saving
- Anti-corrosion and anti-rust

COMPONENT LIST

Material	QTY
Base	2
Leg	4
Beam	1
SUS304 Bolt M10*85 Fastener Kit	4
SUS304 Bolt M10*79 Fastener Kit	4
Rail (U72)	4

ORDERING SPECIFICS

500kW with Ground Screws : 40' Container
 1MW without Ground Screws : 40' Container

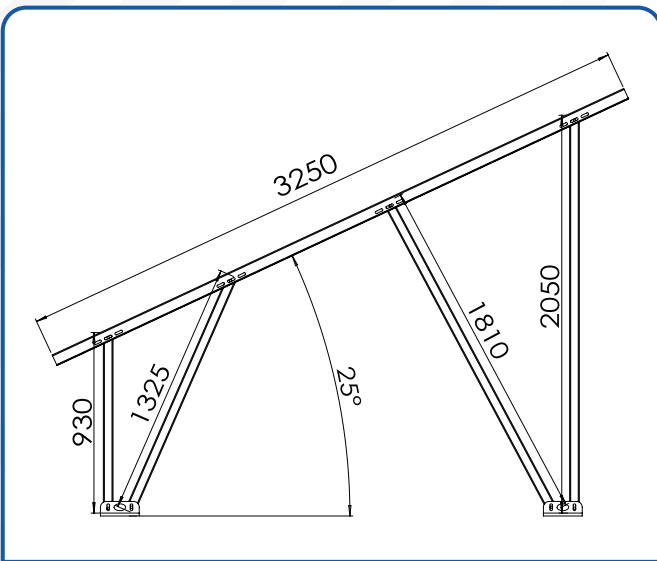

Note: Design According To Project Conditions

WARRANTY



INTERTEK LISTED

